



## Design of Real Time Hybrid Energy Based Charging Station

---

R Prabhu and M. K. Elango

EasyChair preprints are intended for rapid dissemination of research results and are integrated with the rest of EasyChair.

May 21, 2022

# Design of Real Time Hybrid Energy Based Charging Station

R Prabhu<sup>1</sup>, Dr. M. K. Elango<sup>2</sup>

<sup>1</sup>M. E. Power Systems Engineering, K. S. Rangasamy College of Technology, Tiruchengode, Tamil Nadu - 637 215, India.

<sup>2</sup>Professor & Director/EEE, K. S. Rangasamy College of Technology, Tiruchengode, Tamil Nadu - 637 215, India.

<sup>1</sup>prabhuravi78875@gmail.com <sup>2</sup>elango@ksrct.ac.in

## Abstract

Electric vehicles have gained incredible over the past two decades as one of the solutions for optimistic greenhouse gases. Power count vehicles are on the rise around the world; so to user electric vehicles friendly becomes more importance. The main challenge in the use of electric vehicles is required charging time for the batteries used in the electric vehicles. As a result, it the subject matter has been reached across multiple credentials where a wide range of solutions has been proposed. National standards are expected for charging infrastructure will be finalized soon, allowing both public and private electric vehicles. Sector to deploy its charging fleet to meet demand for charge. Centralized strategic planning and charging station location selection is customizable proven to significantly reduce the initial cost required for meet electric vehicle charging demand and reduce range worry. Vehicles to charging station communication have been established to estimate the time of charging. This will help electric vehicles users to know about the charge status and charging station that support fast charging method. All natural dissipation energy is used to produce electricity. Thus electric power or electricity is available anywhere in the world at all times with minimum cost and pollution free. This paper will reveal a new step in the generation of electricity and availability of natural resources without disturbing ecological balance. This paper describes a novel and developing electric power generation mechanism by integrating photovoltaic solar power, wind power and nonconventional energy sources. Thus we have uninterrupted power supply regardless of any type of weather condition. Furthermore this process makes electricity generation is possible with least production cost. The combination of this system will be beneficial in future aspects like commercial power generation, factories, business and hotels and so on.

**Keywords:** Electric Vehicles, Wind Power, Solar Power, Charging Station, Hybrid Energy System

## I. Introduction

Conventional cars produce a lot of carbon dioxide (Co<sub>2</sub>) emissions that are emitted into the atmosphere, causing pollution and greenhouse gases. Today, more attention has been paid to electric vehicles (EVs) as an alternative to

conventional vehicles. The electric vehicle has been developed due to advances in battery technology and motor efficiency. Secondary batteries are the main energy source of electric vehicles. Thus, energy management is a major factor in electric vehicle or hybrid electric vehicle (HEV) design. In addition, the charge capacity of the battery will affect the endurance of electric vehicles. The main challenge in HEV is the required charging time for batteries and the inadequacy of charging stations and therefore charging within the existing distribution system infrastructure is problematic. As of now the Charging station of the HEV is in the range of 100 km per charge due to onboard energy which needs to be optimized. The second challenge for EVs is their battery capacity which ranges from 8.6KWh to 15.2KWh. The resulting disadvantage is that a Level 1 home charger (120V, 50Hz, 15-20A) has over 15 hours of charging time for the above size. Due to these constraints, the vendor (EV charging station supplier) needs a convenient delivery system to meet the customer's demand as well as maximize profits. Special attention should be paid to the charging station. In the future, the number of electric vehicles will increase substantially, these electric vehicles will have to re-charge their batteries in one place (i.e.) charging station, and hence there will be an increasing need for public charging stations. This will have a significant impact on power systems like transformers, protection devices, etc. With respect to varying loads, it will have an impact on consumers and vendors due to traffic at these stations, increased waiting times for charging vehicles, etc. [5].

Thermal power stations are creating pollution which seriously affects mankind and nature. Many diseases result from these power stations. Also natural resources like coal, oil, radioactive material etc., will become extinct in the near future. Other existing power generation systems such as hydro-electricity power generating plants cannot take as much electricity as they are weather-based, although it causes less pollution. Hence, it is very important to go for non-conventional energy resources. The most popular non-conventional energy resource is solar energy which converts solar energy or solar radiation into electricity. The solar power generation system has some drawback, that is, it cannot generate electricity on cloudy or rainy days. Therefore, people using this solar system have to be without electricity after the battery is discharged during the rainy season or in the sun's

shortcomings, as it is completely dependent on the presence of the sun in the sky. Moreover, it has very limited capacity and we cannot take all available solar energy as its efficiency is very low [10]. Hybrid energy system to ensure harvesting efficiency and by using the solar and wind energy generation system the global warming will be reduced. The generated energy by VAWT and solar system are stored in a battery and this stored energy which can be used in the charging station for charging the E-Vehicles on roadways.

## II. Objective

The main objectives of this paper are to use the maximum wind energy from vehicles on highways, the hybrid system of wind and solar in a single setup is structured like a tree and electric vehicles are automatically charged by using E-Charging station.

## III. Proposed System

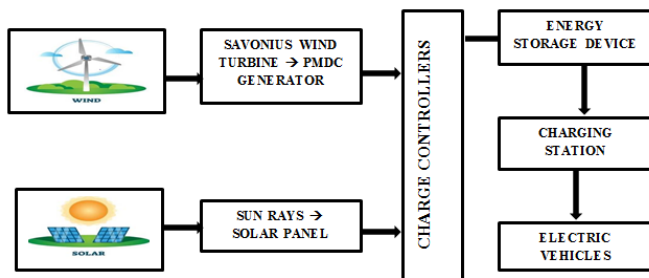

Fig. 1 shows the block diagram of the hybrid energy station

The proposed system consists of generating electrical power by using solar and wind energy [1]. The system consists of two parts one is hybrid system (like a tree structure) and another is automated E-Charging station. The block diagram of the proposed system is shown in Fig.1.

### A. Hybrid System

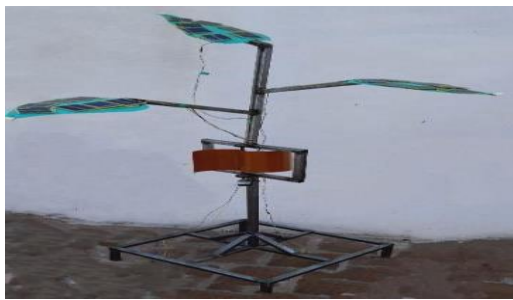

Fig 2 shows the hybrid energy system

Hybrid power system is the combination of two energy sources to power the load. In other words it can be defined as an energy system which is designed or fabricated to extract electricity by using two energy sources; it is called hybrid energy system. Hybrid power system has good reliability, efficiency, low emissions and low cost [4]. The hybrid

systems are used more than one renewable energy sources. In this system combine solar and wind energy has in terms of produced the electric power such systems are said to be a hybrid system is shown in Fig 2. It is possible to combination of energy resources to supply meet the required energy demand [1].

### 1) Wind energy

Wind turbines are converts wind power (mechanical energy) into the electrical power available in the range from 50W to 4 MW. Savonius turbines are one of the simplest and aerodynamically drag-type devices, which is half drums fixed to shaft in opposing directions. Each drum catches the wind, turns the shaft, bringing the opposing drum into a flow of wind, slow rotating with high torque machine direction is works with any direction. Repeat the process the shaft to further rotate and complete the full rotation, starts the low wind speed is very low starting torque. Low noise system and blades like an S letter Shaped in cross section is shown in Fig.3b. The wind turbines works due to different forces exert on each blades. X direction blade is concave half to wind direction caught the wind (Drag Force) to rotate around centre its central vertical shaft. X' direction blades is convex half to wind direction caught the wind (Lift Force) to rotate around causes the air wind to be deflected side around it [2].

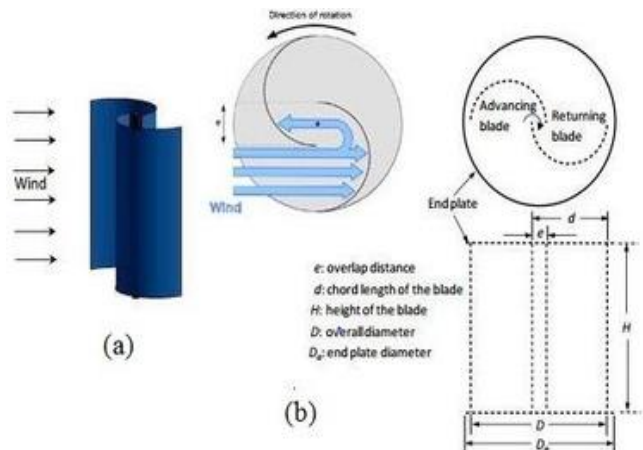

Fig. 3 shows the savonius vertical axis wind turbine

Savonius vertical axis wind turbine has some speed specifications in highways shown in Table 1.

Table 1 Output of wind turbine

WIND SPEED IN HIGHWAYS	VOLTAGE (Volt)	CURRENT (Amp)
25	56.5	1.4
22.23	51.6	1.1
19.45	48.5	0.8
16.67	41.1	0.7
13.88	30.2	0.6
12.5	23.4	0.4
8.34	18.1	0.2

The Fig 3a shows drag and lift forces exert on the two blades savonius because of the blades curvature the blades experience less drag forces when moving against the wind direction. The half concave side cylinder facing the wind will experience more drag force than other half convex cylinder, thus forcing rotating the rotor and differential drag causes spins the savonius turbine [6]. For the reason, turbine extract much low wind power than other similarly sized lift type turbines because of power might be captured has used up pushing the convex half. So savonius wind turbine efficiency has low.

## 2) Solar energy

Solar energy is the energy that we get in the form of radiation from the sun. It does not cause any kind of pollution, it is renewable. It is available for free. Especially, in a country like India where the sun shines about 300 days a year, it is a convenient way of generating electricity [7]. There is very little investment in setting up a solar power plant and it is also quite easy to maintain. The efficiency of the system is also better. Its major advantages are long life span and low emission of pollutants. PV systems can be economically, feasible and large extend the growth of a region. It can be easily penetrate in remote areas the electrical powers are reliable, independent sources and there is no pollution. It can be produce electric current during cloudy days and produces a direct current.

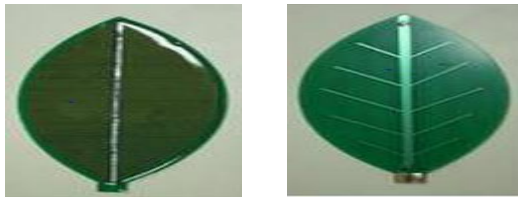

Fig. 4 shows the leaf shaped solar panel

Leaf shaped solar collectors have some specifications shown in Table 2. PV systems are works in order to function in unfavourable condition and small in weight shows in Fig. 4.

Table 2 specifications of solar leaf

Efficiency	>13%
Power $P_{AV}$	1.25W
Voltage, $V_{OC}$ $V_{MAX}$	5.37 V 5V
Current, $I_{SC}$ $I_{MAX}$	280 mA 250 mA
Shape/Colour Weight	Leaf/Green/ 45g
Module Size	170.52(H)x83.5(V) x3(D)mm

It can be installed in any location may be possible where the sun light beams can reach on PV cell surface like on roofs of the buildings, on the ground and so on. To increase the efficiency in the hybrid tree many of the leaf shaped panels are placed.

## B. Automated E-Charging Station

Block diagram for charging Station is shown in Fig. 5.

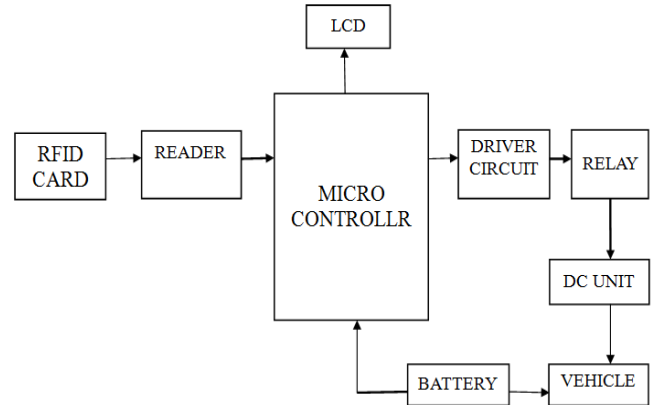

Fig. 5 shows block diagram for charging station

Radio frequency identification refers to a small electronic device serves as a bar code, ATM card or magnetic strip on the credit card. RFID provide a unique identifier of the object. Magnetic strips or bar code are scanned to get the information about the vehicles, must be retrieve the identifying information [1].

The controller controls the signals that reads and stored the data. The driver circuit helps relay works as on/off switch. When microcontroller reads the input (Vehicle information) this can access the tag and verify to start the process open the relay to start the charging process to electric vehicles. After complete the charging the relay switch to be closed and stopped the charging process. The process of a DC/AC unit of charging is shown in Fig. 5. An electric vehicle charging station is an element in infrastructure that supplies electric power for charging the electric vehicles.

Table 3 Output level of charging speed

Parameters	AC Level 1	AC Level 2	DC Fast Charge
Voltage	120V 1-phase AC	208V or 240V 1-Phase AC	208V or 480V 3-Phase AC
Current	12-16 AMPS	12-80 AMPS	<125 AMPS (Typ. 60 Amps)
Charging Loads	1.4 to 1.9 KW	2.5 to 19.2 KW (Typ. 7 KW)	<90 KW (Typ. 50 KW)
Charging Time for Vehicles	3-5 Miles of Range Per Hour	10-20 Miles of Range Per Hour	80% Charge in 20-30 Minutes

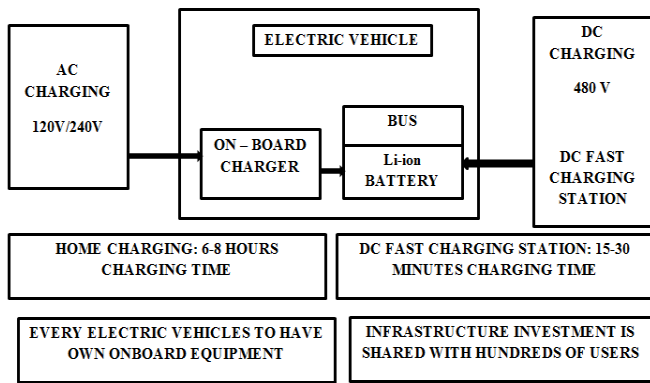

Fig. 6 shows block diagram for charging station

The charging time depend upon the charging power and battery capacity. The rate of time of charging depends on the charging level used on the voltage handling of the batteries and charger in the electric vehicles is shown in Fig. 6. There are the different levels of charging an electric vehicle shown in Table 3.

- ❖ Level 1 AC Charging (120V) at charging stations
- ❖ Level 2 AC Charging (240V) at charging stations
- ❖ Level 3 DC Fast charging at charging stations (480V)

For an electric vehicles have own on board equipment and the infrastructure investment is shared with hundreds of users.

#### IV. EXPERIMENTAL SETUP

The hardware module consists of various electrical and electronic components such as power supplies, batteries, microcontrollers, relays, RFID, DC motors. Apart from these charging stations, solar panels and windmills are available in this module. The function of relay and motor is controlled by microcontroller activated from battery source. The charge is collected in the battery.

The hardware module (hybrid tree) containing the solar and the savonius vertical wind turbine, both of which are connected to the battery. The leaf-shaped solar panel consists of hybrid tree as shown in Fig. 7a. The savonius wind turbine is placed at the center of the hardware module; it is in the "S" shape as shown in Fig 7b.



(a)

(b)

Fig. 7a & 7b Shows in hardware top view and side view

#### V. OUTPUT ANALYSIS

The charging stations consist of both AC and DC Supply for charging the AC (Level 1 and Level 2) and DC (Level 3 or fast charging) electric vehicle. This charging station is fully automated and controlled by RFID and relay for an particular time. The operation of charging stations is shown in Fig. 8 and Fig. 9.

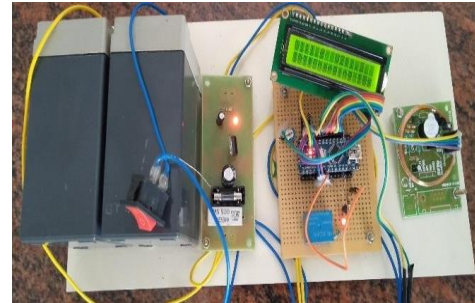

Fig. 8 charging ON state

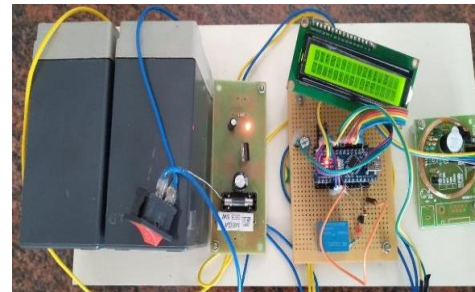

Fig. 9 charging OFF state

Steps to charging the electric vehicles are shown in Fig.10.



Fig. 10 Shows that the vehicle charging process

Step1: Read the RFID in the vehicles.

Step 2: Once RFID is verified. Entire vehicle data read by RFID card reader and it stored in the microcontroller. If battery is low access granted for charging the electric vehicle otherwise access denied.

Step 3: Driver circuit is active the relay to ON condition for charging the vehicles. Hence charging is completed relay will be OFF.

Step 4: Charging state are displayed in the LCD display.

## VI. MANUAL CALCULATION

The core modules and functionality are featured

### Battery Performance Analysis

The important components of a battery are energy density, charging time, lifetime and cost. All of these charging times have a greater dependence on the performance of the battery. The control parameters of the charging process are voltage (V), current (I), temperature, input energy and output energy. Charging time (CT) and the discharging time (DT) of the battery is calculated using the equation (1) and (2)

$$CT = \frac{\text{Battery Rating}}{I} \quad (1)$$

$$DT = \frac{\text{Battery Rating} * V}{\text{Load applied}} \quad (2)$$

The discharge rate is also affected by the current rate (C-rate). The C rate is the rate in amperes, while the nC rate would be discharge the battery in 1/n hour. For examples is shown in Table 4. C depends on the battery discharge current rate according to Peukert's equation. Peukert's position is that the batteries will discharge faster than expected. Peukert's equation is shown in equation (3).

$$\text{Pack size usable} = 0.80 * KW * \text{Peukert's constant} \quad (3)$$

Table 4 Shows the C-rate

nC Rate in amperes	Discharge a Battery
C/2	2 hours
5C	0.2 hours
30C	0.033 hours

For lead acid batteries, the Peukert's constant can range from 2.0 to 1.0 depending on the manufacture technology. The lithium-ion battery supports a charging temperature of 0°C to 45°C (32°F to 113°F) and Discharge temperature of -20°C to 60°C (-4°F to 140°F). Charging below freezing point is not allowed. Good charging and discharging performance at high temperatures but longer battery life will be affected [8].

### EV Module

#### Home charging point

This is a simple home charging point where the EV is plugged into a standard socket in a residential building, the input varies from country to country for example 240 volts (in India), 120 volts (in USA). It takes over 4–11 hours to charge the EV to its full capacity with an expected power level of 1.4 kW (12 A) for a battery capacity of 5–15 kW, but this is the most efficient compared to other levels of charging. Easy and cheap way EV charging

#### Public charging station

This is the most appropriate and common way to charge electric vehicles, as they contain specialized equipment that provides a high degree of protection. These are used for

charging electric vehicles in public places. They can be of two types either conductive or inductive. The conductive type is further classified into two butt types, pin and sleeve types. Input for level 2 charging is 400 volts (in India), 240 volts (in USA) and the expected power level is 4KW (17A) 5-15KWh. It takes about 1-4 hours to charge a battery with a capacity.

### Cost Analysis of charging station

The total cost of the hybrid energy system is depends upon the number of battery used, total number of solar leaf shaped panel used and total number of savonius vertical axis wind turbine used. Hence the total cost is given in equation (4).

$$\text{Cost} = \text{No. of Battery Used} * \text{Cost Per Battery} + \text{No. of Solar Leaf Panel Used} * \text{Cost Per Solar Leaf} + \text{No. of savonius VAWT Used} * \text{Cost Per Single savonius VAWT} \quad (4)$$

**in Rupees**

### Power Analysis of Hybrid Tree

#### Solar energy

The required energy consumption must be estimated by determine the size of PV module is shown in equation (5). Power calculated as

$$P_s = [\text{Area of one leaf shaped panel (in m}^2\text{)} * \text{Isolation at time (Kw/m}^2\text{)} * \text{Annual avg solar radiation} * \text{Coefficient for losses}] \text{ in Watts} \quad (5)$$

#### Wind energy

The wind power [ $P_w$ ] generated by wind energy is shown in equation (6). Power calculated as

$$P_w = \frac{1}{2} [(\text{Wind speed (in m/s)})^3 * \text{Swept Area by air (in m}^2\text{)} * \text{Air Density in (kg/m}^3\text{)}] \quad (6)$$

### Total power calculation

The power generated by this hybrid system as the addition of wind turbine generated power and solar PV panel generated power is shown in equation (7). It can be represented by mathematically,

$$\text{Total Power} = [\text{Number of wind turbine Used} * \text{Power generated by wind turbine}] + [\text{Number of solar leaf Used} * \text{Power generated by solar energy}] \text{ in Watts} \quad (7)$$

## VII. Advantage

By using of hybrid system has low cost, high efficiency and reliability. Hybrid energy system has many advantages over

than non-renewable energy sources and have greater available in all areas. To install the system anywhere there is no need to specify for the particular locations.

### VIII. Conclusion

The integration and use of renewable energy sources is in great demand in commercial sectors where the need for electricity is high and will be effectively everywhere. The effective solution, using this hybrid system, is the most convenient and reliable renewable energy or low cost resource. Using this system saves charge as it is very low maintenance and not only costly but it also does not cause any harm to the environment. The result is more reliable in hardware and no power failure. E-vehicles are the best solution for green energy to make the environment pollution-free and vehicles running on non-renewable fuel generate pollution so green energy is the best replacement.

### IX. Future Scope

In future this project can be extended to trains and metro trains as their speed is higher than road movable vehicles. This stored energy is further used for agricultural fields and rural electrification. And, as a future real it could use vertex blades as a new radial way to generate wind power. In addition, the overall efficiency of the model could be increased by installing turbines near tunnels, using piezo-electric materials in place of wind turbine blades, among other improvements. Planting multiple hybrid trees in roadways increases electrical power. Then it uses to charge the electrical appliances like electric vehicle, mobile charging etc.

### REFERENCES

- [1] N.Sivaramakrishna, Ch.kasi Ramakrishna Reddy,” Hybrid Power Generation through Combined Solar Wind Power and Modified Solar Panel”, IJETT- Volume 4, Issue 5, May-2013, ISSN 2231-5381.
- [2] M. M. Ramya, D. Vinothkumar, K. Rajeshwari, S. Soorya, M. Subramani, “Hybrid energy harvesting system for charging stations”, IRJET, Volume:06 Issue:03, e-ISSN: 2395-0056, p-ISSN: 2395-0072, Mar 2019.
- [3] K. Ramesh, C. Bharatiraja and Raghu Selvaraj, “Design and Implementation of Real Time Charging Optimization for Hybrid Electric Vehicles”, IJPEDS – Volume 7, No. 4, December-2016.
- [4] Yajing Gao, Yandong Guo, “Optimal Planning of Charging Station for Phased Electric Vehicle”, EPE – Scientific Research, May-2015.
- [5] Chellaswamy, V. Nagaraju, R. Muthammal, “Solar and Wind Energy Based Charging Station for Electric vehicles”, in IJAREEIE, Volume 7, Issue 1, January 2018.
- [6] Pritesh P. Shirsath, Anant Pise, Ajit Shinde, “Solar-Wind Hybrid Energy Generation System”, in IJERGS, Volume 4, Issue 2, March-April, 2016, ISSN 2091-2730.
- [7] Abhishek Moyal, Rahul Sharma,” Design and Comparative Evaluation of a Hybrid Wind-Solar Power System”, IJEMS, ISSN-2348 –3733, Volume-1, Issue-4, April 2014.
- [8] Poorani S,” Hybrid Power Generation by Using Solar and Wind Energy Hybrid Power Generation Applicable To Future Electric Vehicle”, IJETST, Volume 04, Issue 11, Pages 6285-6294, November 2017, ISSN 2348-9480.
- [9] Bharat Raj, Ba Krishna Dubey, “Solar-Wind Hybrid Power Generation System”, IRJET, volume 05, Issue 01, Jan 2018.
- [10] Sandeep Kumar, Vijay Kumar Garg,” A Hybrid Model of Solar-Wind Power Generation System”, IJAREEIE, Volume 02, Issue 08, Aug 2013.