



Methanol Synthesis from Syngas: a Process Simulation

Ramesh Timsina, Rajan Kumar Thapa,
Britt Margrethe Emilie Moldestad and
Marianne Sørflaten Eikeland

EasyChair preprints are intended for rapid dissemination of research results and are integrated with the rest of EasyChair.

September 20, 2021

Methanol synthesis from syngas: a process simulation

Ramesh Timsina* Rajan k. Thapa Britt M.E. Moldestad Marianne S. Eikeland

Department of Process, Energy and Environmental Technology, University of South-Eastern Norway, Porsgrunn
{[ramesh.timsina](mailto:ramesh.timsina@usn.no), [rajan.k.thapa](mailto:rajan.k.thapa@usn.no), [britt.moldestad](mailto:britt.moldestad@usn.no), [marianne.eikeland](mailto:marianne.eikeland@usn.no)}@usn.no

*Corresponding author: ramesh.timsina@usn.no

Abstract

Methanol is one of the major candidates to take over the petroleum based liquid transportation fuel. Methanol synthesis from syngas is proposed in this paper. The Aspen Plus simulation software was used to simulate the conversion process from syngas into methanol. A CSTR reactor with defined reaction kinetics was taken at 40 bar and 270°C to simulate the methanol synthesis. Hydrogen recycles gave an increase of 50.4% in the production of methanol as compared to the results without a H₂ recycle stream. The conversion of CO, CO₂ and H₂ are 50.4%, 99.8% and 100% respectively for the case with the H₂ recycle. Considering an operation of 8600 hr/year, the annual mass production of methanol is equal to 96492 tonnes for a feed rate of 154972 t/year. A distillation column is used to separate the methanol from water. Simulations were performed to calculate the minimum number of stages for the different recovery ratios of methanol in distillate and the required molar reflux ratio versus the purity of methanol in the distillate. The column temperature and the composition profile were analyzed for the column. The model provides the insights of the methanol synthesis plants for a specific quality and the quantity of methanol production.

Keywords: *methanol synthesis, Aspen Plus, process simulation, CO₂ mitigation, Distillation.*

Abbreviations: *CSTR - Continuous Stirred Tank Reactor, GHG - Green House Gas, STM - Syngas to Methanol, TPC - Thermo-Photo Catalyst,*

1 Introduction

The increasing environmental problems due to the excessive use of fossil fuels have led to implementing laws and agreements to limit global Green House Gas (GHG) emissions. Several countries agreed to the objective of the Paris Climate Change Conference

(COP21), i.e. to limit the rise of global temperature less than 2°C by 2035 as compared to the preindustrial era (Dessens *et al.*, 2016). Thus, biomass is one of the promising alternatives for the replacement of fossil fuels based liquid transportation fuels in the near future. As compared to the other renewable energy sources, biomass can be converted into added-value products similar to that of fossil fuels and power (Puig-Gamero *et al.*, 2018).

Lignocellulosic biomass and biomass waste can be converted into value-added chemicals and biofuels via thermochemical or biochemical conversion. The biochemical route is complex and more expensive than thermochemical conversion (Sikarwar *et al.*, 2017). Among the different thermochemical conversion technologies, gasification is considered the cost-effective and efficient technology for lignocellulosic biomass (Sikarwar *et al.*, 2017). The lower emission of GHGs is due to the low-oxidation environment and lower amount of sulfur and nitrogen present in the biomass (Kumari & Mohanty, 2020; Pauls *et al.*, 2016). Gasification of biomass gives a product gas mainly consisting of syngas (CO, H₂). However, the gas also contains CH₄, CO₂, H₂O, N₂ and impurities such as tars, NH₃, H₂S.

After gas cleaning and conditioning, the syngas obtained from biomass gasification can be used to produce biofuels and chemicals such as methanol.

Methanol is one of the important industrial chemicals that can be used directly as a fuel or can be blended into conventional fuels. Methanol is an important ingredient for the production of formaldehyde, acetic acid, methyl tertiary butyl ether, and gasoline.

China is the leading producer of methanol, approximately 50% of the global production and a total of 43 million tons was produced in 2016 (Yang *et al.*, 2018). However, methanol production is mainly based on natural gas and coal. Olah *et al.* (Olah, 2005) proposed a ‘methanol economy’ as a realistic technique compared to the widely mentioned ‘hydrogen economy’ due to the suitability of the existing liquid fuel

infrastructure (with a little modification) and higher safety compared to a hydrogen vehicle.

The current study gives insights into a methanol synthesis plant, its production scale. A study of the distillation column was done in greater detail. The column temperature and composition profile are presented. The relation between the minimum number of stages for the different recovery ratios of methanol in distillate and the required molar reflux ratio versus the purity of methanol in the distillate are presented in the paper.

2 Methanol synthesis from syngas and carbon dioxide

As the synthesis gas stream usually contains some amounts of CO₂, methanol can be produced via direct hydrogenation of CO and CO₂. Table 1 shows the reactions concerning the methanol synthesis and their reaction heats. Reaction (c) is the reverse water gas shift reaction which is mildly endothermic as opposed to reactions (a) and (b). Therefore, a significant amount of cooling duty is required for these types of reactors. The thermodynamics of the conversion limits the overall conversion and thus recycling of the unreacted gas is required to achieve higher conversion. Therefore, cooling duty and recycling capacity determines the successful operation of such reactors.

The mixture of CO and H₂ can also react to produce other hydrocarbons such as methane, ethanol, or higher hydrocarbons. Therefore, the selectivity and efficiency of the catalyst play an important role in the conversion efficiency of these types of reactors.

The methanol synthesis reactor requires a specific ratio of CO/CO₂:H₂, and it is hard to obtain the desired ratio directly from a gasifier. The ratio needs to be

shifted to a higher hydrogen content and is usually done via a water gas shift reaction. Two moles of H₂ are needed to react with CO and three moles of H₂ are needed to react with CO₂ for methanol formation according to the reaction stoichiometric given in Table 1.

Table 1. Reaction formulas for methanol synthesis

Reactions	Reaction heat (kJ/mol)
(a) $\text{CO} + 2\text{H}_2 \rightleftharpoons \text{CH}_3\text{OH}$	-90.64
(b) $\text{CO}_2 + 3\text{H}_2 \rightleftharpoons \text{CH}_3\text{OH} + \text{H}_2\text{O}$	-49.67
(c) $\text{CO}_2 + \text{H}_2 \rightleftharpoons \text{CO} + \text{H}_2\text{O}$	+41

2.1 Previous works

Different literature studies on methanol production are based on different feedstock such as natural gas (Al-Sobhi & Elkamel, 2015; Kralj & Glavič, 2009), synthesis gas (Lange, 2001), CO₂ hydrogenation (Van-Dal & Bouallou, 2013) and coal (Li *et al.*, 2018).

Methanol synthesis has been a wide research topic over the years. Methanol synthesis from syngas was first suggested by Paul Sabatier in 1905 and the first industrial scale plant came into operation in 1923 by Badische Anilin-und-Soda-Fabrik (BASF). The technology has been studied extensively during the 1970's Arab Oil Embargo, as an alternative to fossil-based petroleum (Wu-Hsun 1994).

Inlet temperature, reactor pressure and temperature, reactor types, catalysts system and process configurations have been the most investigated parameters. Hoseiny *et al.* (Hoseiny *et al.*, 2016) and Manenti *et al.* (Manenti *et al.*, 2011) have investigated

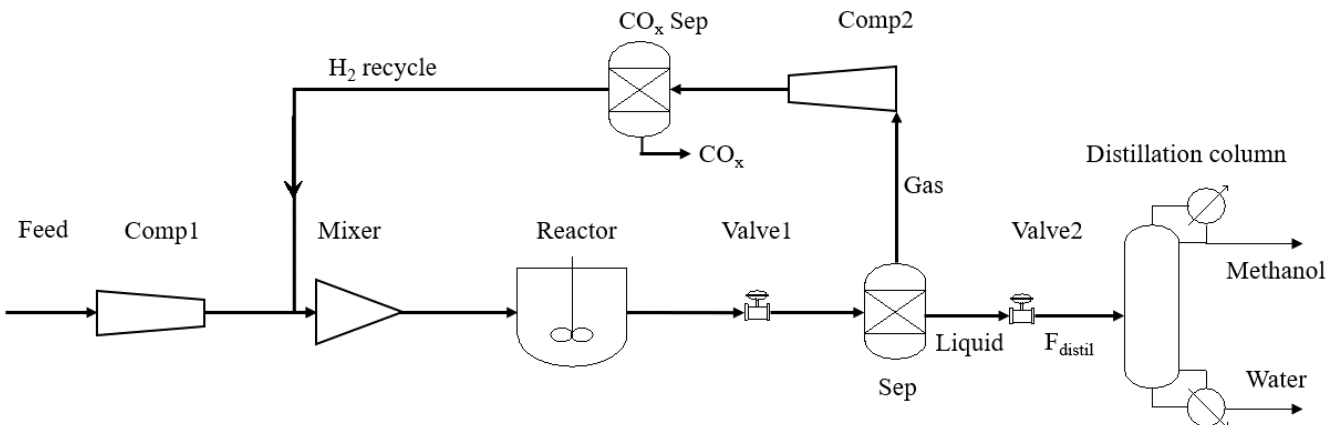

Figure 1. Schematic diagram for Aspen Plus model. Comp: Compressor, Sep: Separator, CO_x: Carbon oxides

the influence of feed temperature and reactor pressure in the methanol synthesis.

Cui and Kær (Cui & Kær, 2020) have studied the three different types of reactors i.e., adiabatic, water-cooled and gas-cooled reactor to investigate the traditional syngas to methanol (STM) process. The water-cooled reactor showed efficient heat removal, low hot-spot temperature and a relatively wide range of inlet temperature for control. The adiabatic reactor and the gas-cooled reactor demonstrated a relatively low and medium performance and low to medium capital costs (Cui & Kær, 2020).

Wu et al (Wu *et al.*, 2019) have developed a novel thermo-photo catalyst (TPC) for methanol production from syngas over Cu/Zn/Al catalyst. The authors demonstrated that the yield of methanol from TPC was 2.8 times higher than that from the thermal catalyst. TPC proved to be superior as compared to the thermal catalyst for the STM process.

Luyben (Luyben, 2010) has developed an economically feasible design for methanol production with three gas recycle streams to produce high quality methanol from syngas. Luyben showed a tradeoff between reactor pressure and feed compressor energy, reactor size and recycle flow rate, venting rate and reactant losses and flash pressure and flash compression energy (Luyben, 2010).

3 Materials and methods

Aspen Plus V11 was used to simulate the conversion of syngas into methanol. The process model developed in Aspen Plus is presented in Figure 1. The ‘RK-Aspen’ physical properties model was used for all the unit operations except the distillation column. Van Laar equations were used in the distillation column for the calculation of liquid activity coefficients. Different components as present in Table 4 were also defined in the physical property’s environment. Table 4 also gives the mass flow rate for the different gases present in the feedstock and the molar ratio of CO:CO₂:H₂ is 1:3:10. A total of 11 moles is required to react completely with 1 mole of CO and 3 moles of CO₂, however, 10 moles of H₂ were taken due to the presence of the H₂ recycle path. The following assumptions were considered for the simulation process.

1. All gases were ideal.
2. Pressure and temperature were uniform inside the reactor.
3. The process was steady and isothermal.

4. The synthesis gas is pure and is supplied at a specified molar flow rate.

The standard operating condition for the methanol synthesis reactor are in pressure and temperature in the range of 50-100 atm and 220-280°C respectively (Ortiz *et al.*, 2013). The blocks used to simulate the methanol synthesis are summarized in Table 2.

Table 2. Block description used for methanol synthesis

Name	Type, description
Comp	Compressor: Both compressors compress the gases into 40 bars.
Reactor	RCSTR: Rigorous continuous stirred tank reactor with rate-controlled reactions based on known kinetics.
Sep	Separator: Separates liquids and gases.
CO _x Sep	Separator: Separates CO _x from H ₂ .
Distillation column	RadFrac: Rigorous 2 or 3- phase fractionation for single columns.

The pure syngas feed was compressed and heated up to the reactor operating pressure and temperature. Exothermic gas phase reactions were defined in the reactor for the synthesis of the methanol. The defined reactions in the reactor are presented in Table 1 and the reaction kinetics were taken from the study of Luyben (Luyben, 2010). The product from the reactor is depressurized to separate the non-converted gases from the liquid. The liquid enters into the distillation column to give methanol in the distillate and water in the bottom.

Table 3. The thermodynamic state of different units/flows

	Thermodynamic state	
	Temperature(°C)	Pressure (bar)
Feed	50	1
Comp1	-	40
Reactor	270	40
Valve1	-	10
Sep	60	10
Comp2	-	40
CO _x Sep	270	40
Valve2	-	1.5
F _{distil}	60	1.5

The conversion of hydrogen at this stage (without a recycle stream) is only about 50%, therefore a recycle stream is chosen to increase the hydrogen conversion. The separated gas is compressed to separate CO_x in another separator. H₂ separated from the CO_x separator enters the mixer before the reactor as a recycle feed. The

overview of the temperature and pressure in the different blocks and streams is presented in Table 3.

The methanol-water separation is fairly easy and is performed at 1.4 bar condenser pressure and 1.7 bar reboiler pressure. Txy diagram at 1.5 bar pressure is given in Figure 2. The plot gives the temperature range at which the distillation column should operate to give higher purity of methanol in the distillate. In the simulated case, the distillation column operates in the temperature range of 74.9 to 100.15°C.

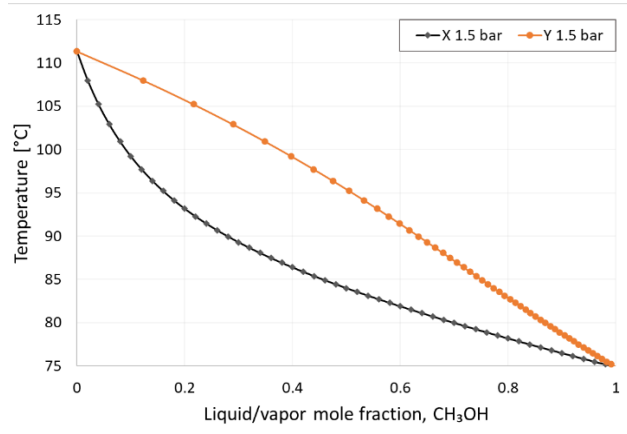

Figure 2. Txy diagram for methanol/water

A total condenser is selected for this simulation as sufficient cooling is available as the feed consists of 32.5 mass% of water at 60°C. This water is sufficient to condensate all the condensable vapor generated at the column overhead.

4 Results and discussion

Table 4 shows the mass balance for the simulated case. The table shows the yield of 2.33 tonnes of methanol per tonne of syngas (CO+H₂) supplied [calculated as $\text{methanol_out}/(\text{CO_in} + \text{H}_2\text{_in})$]. Considering an operation of 8600 hr/year, the annual mass production of methanol is equal to 96492 tonnes. The conversion of CO, CO₂ and H₂ are 50.4%, 99.8% and 100% respectively and the results are similar to the study of Luyben (Luyben, 2010).

Table 4. Mass balance for the simulated case

Compound	In (t/hr)	Out (t/hr)
CO	2.8	1.39
CO ₂	13.2	0.01
H ₂	2.02	0
Methanol	0	11.22
H ₂ O	0	5.40

Several studies by different researchers show that methanol mainly originates from the CO₂ hydrogenation, and hardly from the CO hydrogenation (Kagan *et al.*, 1975; Nestler *et al.*, 2018). Therefore, CO conversion to methanol principally occurs via water gas shift reaction with subsequent CO₂ hydrogenation.

Simulations were performed to know the minimum number of stages for the desired recovery of methanol in distillate and the required molar reflux ratio for the desired purity of methanol in the distillate.

Figure 3 shows the minimum number of stages required to achieve the methanol recovery from 0.9 to 1. The number of minimum stages required increases linearly for up to around 98% methanol purity and increases exponentially after 98%. As most of the industrial scale, methanol synthesis plant operates at around 95% purity of methanol, which is relatively straightforward and doesn't overburden the column cost.

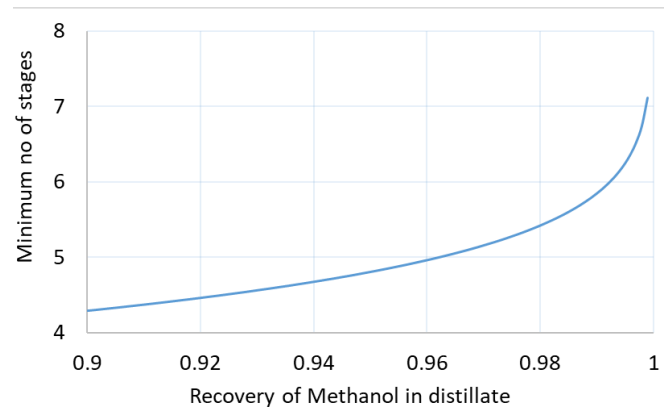

Figure 3. Minimum number of column stages required for corresponding methanol recovery

Figure 4 shows the purity of methanol for different molar reflux ratios. The purity of methanol increases with an increase in the molar reflux ratio, however the reboiler duty and cost increase linearly with an increase in reflux ratio. The purity of methanol synthesis increases steadily initially and exponentially for the higher methanol purity. Therefore, a tradeoff is required for the reflux ratio and the desired methanol purity in the column distillate.

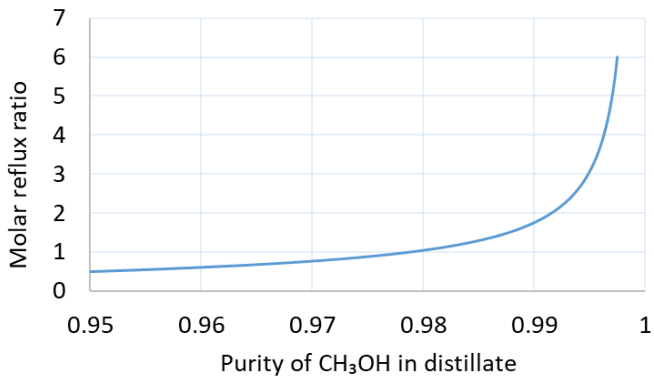

Figure 4. Molar reflux ratio vs methanol purity in distillate

As the total number of stages increases, energy costs and heat exchanger capital costs decrease, however, the total capital costs of the plant will increase. Therefore, a rigorous single distillation column with 7 stages was chosen to separate water from methanol. The selected number of stages gave the desired purity of methanol (95 mass percentage) in the distillate. The temperature profile across the stages is presented in Figure 5 and the liquid molar composition across the stages is presented in Figure 6. Stage 1 is the top of the column and stage 7 is the bottom of the distillation column.

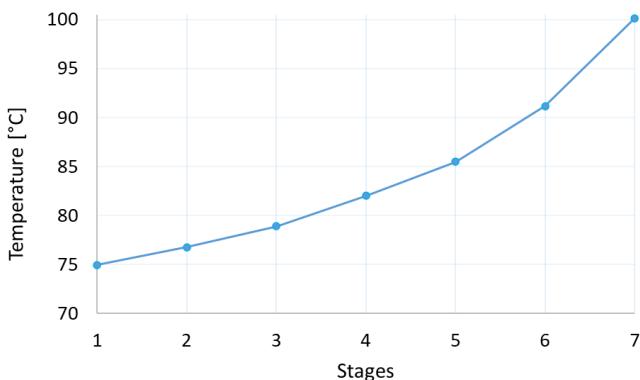

Figure 5. Column temperature profile

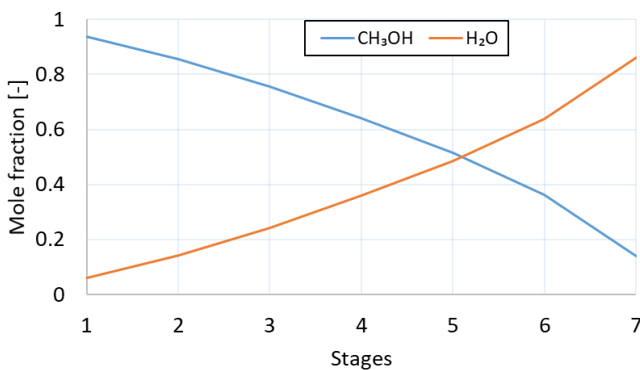

Figure 6. Column composition profile

The figure illustrates a gradual decrease in temperature from the bottom of the tower to the top of

the distillation tower. The change of composition of methanol increases steadily from the bottom (stage 7) to the top (stage 1) and the mole fraction of water decreases steadily from the bottom to the top of the distillation tower.

The higher the system pressure, the smaller the reactor for a given recycle flow rate, which reduces the reactor and catalyst capital investment. However, for a given reactor size, the higher the pressure, the smaller the recycle flow rate, which reduces the recycle compressor capital investments and recycle compression energy.

Therefore, the design specification for a methanol synthesis plant depends upon the different parameters such as system pressure, temperature, reactor size, recycle flow rate, compressor energy, reflux ratio in the distillation column and the purity of methanol in the distillate.

Sensitivity analysis for the CSTR reactor showed relatively low sensitivity towards the change of temperature and pressure inside the reactor in the range of 220-280°C and 40-100 bar. The change in reactor pressure from 40 bar to 100 bar gave an increase of 1.7% in methanol production. Temperature variation from 220-280°C gave a 0.02% reduction in methanol synthesis.

5 Conclusion

A steady-state Aspen Plus™ model was developed to study the conversion of syngas into methanol. Simulations were performed to analyze the conversion process. The model was used to study the different integral parts of a methanol synthesis reactor such as compressor, heater, reactor, separator, and distillation column. The desired purity of methanol in the distillate was 95%. In order to achieve this for the given mass flow rate, a 7-stage rigorous two-phase single column was used.

The following results were obtained from the distillation column for the specified thermodynamic conditions.

- $\frac{\text{CH}_3\text{OH in distillate}}{\text{CH}_3\text{OH in feed}}$: 87.1%
- Distillate to feed ratio: 0.5
- Reflux ratio (molar): 1.2
- Purity of methanol in distillate: 96.4%
- Methanol production: 96492 tonnes/year

A cooling duty of 23.62 GJ/hr was required for the given flowrate specifications and a reactor size of 5 m³.

The model can further be improved by adding a suitable catalyst in the reactor, selecting/optimizing the reaction kinetics as well as performing the sensitivity analysis for the synthesis reactor. The distillation column can be optimized further based on the required specification for the methanol plant.

Acknowledgments

The authors would like to thank the University of South-Eastern Norway (USN) for providing the necessary software for the simulation works. The authors would like to acknowledge the Bio4Fuels projects in Norway.

References

- S. Al-Sobhi and A. Elkamel. Simulation and optimization of natural gas processing and production network consisting of LNG, GTL, and methanol facilities. *Journal of Natural Gas Science and Engineering* 23, 500-508, 2015. doi.org/10.1016/j.jngse.2015.02.023.
- X. Cui and S. K. Kær. A comparative study on three reactor types for methanol synthesis from syngas and CO₂. *Chemical Engineering Journal*, 393, 124632, 2020. doi.org/10.1016/j.cej.2020.124632.
- O. Dessens, G. Anandarajah and A. Gambhir. Limiting global warming to 2° C: What do the latest mitigation studies tell us about costs, technologies and other impacts? *Energy Strategy Reviews*, 13, 67-76, 2016. doi.org/10.1016/j.esr.2016.08.004.
- S. Hoseiny, Z. Zare, A. Mirvakili, P. Setoodeh and M. Rahimpour. Simulation-based optimization of operating parameters for methanol synthesis process: application of response surface methodology for statistical analysis. *Journal of Natural Gas Science and Engineering*, 34, 439-448, 2016. doi.org/10.1016/j.jngse.2016.06.075.
- Y. B. Kagan, L. Liberov, E. Slivinskii, S. Loktev, G. Lin, A. Y. Rozovskii, and A. Bashkirov. Mechanism of methanol synthesis from carbon dioxide and hydrogen. [Tracer study of conversion over Cu-Zn-aluminium oxide SNM-1 catalyst]. *Dokl. Chem.(Engl. Transl.);(United States)*, 221. 1975
- A. K. Kralj, and P. Glavič. Multi-criteria optimization in a methanol process. *Applied Thermal Engineering*, 29(5-6), 1043-1049, 2009. doi.org/10.1016/j.applthermaleng.2008.05.015.
- P. Kumari and B. Mohanty. Maximization of hydrogen production from pine needles steam gasification based on response surface methodology. *Biomass Conversion and Biorefinery*, 1-14, 2020. doi.org/10.1007/s13399-020-00761-7.
- J.-P. Lange. Methanol synthesis: a short review of technology improvements. *Catalysis Today*, 64(1-2), 3-8, 2001. [doi.org/10.1016/S0920-5861\(00\)00503-4](https://doi.org/10.1016/S0920-5861(00)00503-4).
- C. Li, H. Bai, Y. Lu, J. Bian, Y. Dong, and H. Xu. Life-cycle assessment for coal-based methanol production in China. *Journal of Cleaner Production*, 188, 1004-1017, 2018. doi.org/10.1016/j.jclepro.2018.04.051.
- W. L. Luyben. Design and control of a methanol reactor/column process. *Industrial & Engineering Chemistry Research*, 49(13), 6150-6163, 2010. doi.org/10.1021/ie100323d.
- F. Manenti, S. Cieri, and M. Restelli. Considerations on the steady-state modeling of methanol synthesis fixed-bed reactor. *Chemical Engineering Science*, 66(2), 152-162, 2011. doi.org/10.1016/j.ces.2010.09.036.
- F. Nestler, M. Krüger, J. Full, M. J. Hadrich, R. J. White, and A. Schaadt. Methanol synthesis—industrial challenges within a changing raw material landscape. *Chemie Ingenieur Technik*, 90(10), 1409-1418, 2018. doi.org/10.1002/cite.201800026.
- G. A. Olah. Beyond oil and gas: the methanol economy. *Angewandte Chemie International Edition*, 44(18), 2636-2639, 2005. doi.org/10.1002/anie.200462121.
- F. G. Ortiz, A. Serrera, S. Galera, and P. Ollero. Methanol synthesis from syngas obtained by supercritical water reforming of glycerol. *Fuel*, 105, 739-751, 2013. doi.org/10.1016/j.fuel.2012.09.073.
- J. H. Pauls, N. Mahinpey, and E. Mostafavi. Simulation of air-steam gasification of woody biomass in a bubbling fluidized bed using Aspen Plus: A comprehensive model including pyrolysis, hydrodynamics and tar production. *Biomass and bioenergy*, 95, 157-166, 2016. doi.org/10.1016/j.biombioe.2016.10.002.
- M. Puig-Gamero, J. Argudo-Santamaria, J. Valverde, P. Sánchez, and L. Sanchez-Silva. Three integrated process simulation using aspen plus®: Pine gasification, syngas cleaning and methanol synthesis. *Energy conversion and management*, 177, 416-427, 2018. doi.org/10.1016/j.enconman.2018.09.088.
- V. S. Sikarwar, M. Zhao, P. S. Fennell, N. Shah, and E. J. Anthony. Progress in biofuel production from gasification. *Progress in Energy and Combustion Science*, 61, 189-248, 2017. doi.org/10.1016/j.pecs.2017.04.001.
- É. S. Van-Dal, and C. Bouallou. Design and simulation of a methanol production plant from CO₂ hydrogenation. *Journal of Cleaner Production*, 57, 38-45, 2013. doi.org/10.1016/j.jclepro.2013.06.008.
- X. Wu, J. Lang, Y. Jiang, Y. Lin, and Y. H. Hu. Thermo-Photo Catalysis for Methanol Synthesis from Syngas. *ACS Sustainable Chemistry & Engineering*, 7(23), 19277-19285, 2019. doi.org/10.1021/acssuschemeng.9b05657.
- S. Yang, B. Li, J. Zheng, and R. K. Kankala. Biomass-to-Methanol by dual-stage entrained flow gasification: Design and techno-economic analysis based on system modeling. *Journal of Cleaner Production*, 205, 364-374, 2018. doi.org/10.1016/j.jclepro.2018.09.043.
- C. Wu-Hsun. Methanol Production and Use. *Dekker*, 1994.